



MANUSCRIPTORIUM

A gentle introduction

Tomas Psohlavec, AiP Beroun s.r.o.

June 2014

A gentle introduction.

1. General introduction

- The purpose
- The aggregated contents
- Basic features

2. Partners' essentials

- Aggregation principles
- Ways of cooperation

3. Something more

- More advanced features
- Use cases
- Contacts

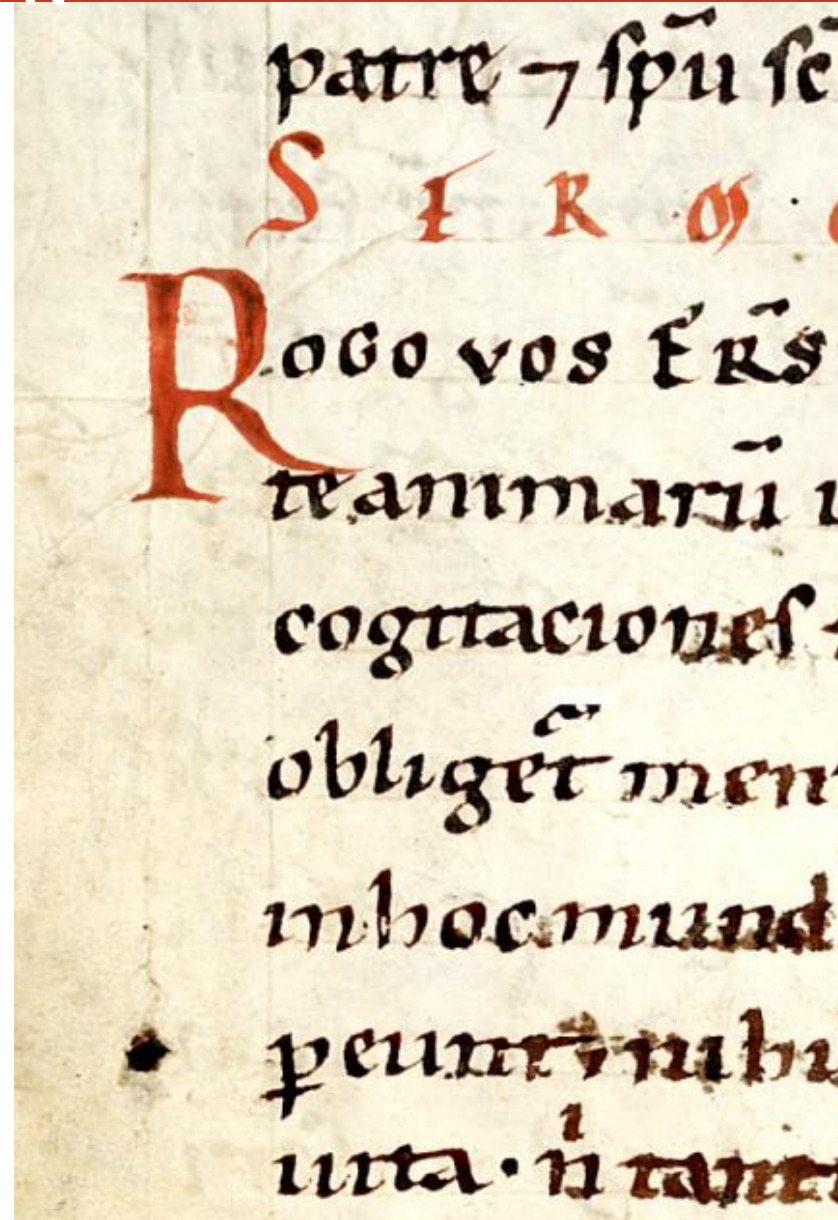



MANUSCRIPTORIUM

1. General introduction

The purpose:

1. We aim to provide seamless access to **all existing digital documents** in the sphere of historic resources.
2. We create a **virtual research environment** and the content is available under a **single digital library interface**.

The aggregated contents:

20+ countries

100+ content providers

The richest owners of rare digitized documents among national libraries, university libraries and other types of institutions.



See partners list at:

<http://v3.manuscriptorium.com/en/aggregated-resources>

The aggregated contents:

24 000+ full digital documents

300 000+ descriptive records

5 000 000+ individual images



Basic features: search and find

1. Search & retrieve records in the catalogue

Simple search form

Available digital copies

Detailed document information

The screenshot displays the Manuscriptorium website interface. At the top, a search bar contains the text 'graduale dominicale' and a dropdown menu is set to 'Words anywhere'. To the right, a user is logged in as 'tomas' with a 'Log out' button. Below the search bar, the results section shows two items: 'Graduale Dominicale' (59.R.5098) and 'Graduale' (XIII.F.20). The 'Graduale Dominicale' record is selected and expanded, showing detailed information under tabs for 'Overview', 'Detail', 'Facsimile (135)', and 'XML'. The 'Identification' section includes fields for Identifier (set20100108_182_16), URI, Shelf-mark (59.R.5098), Repository (Národní knihovna České republiky), Settlement (Praha), and Country (Česko). A small image of a manuscript page is visible. The 'About the document' section lists Title (Graduale Dominicale), Format (codex), Extent (66 ff. 160 205), Medium (chart), and Provenance (V pravém horním rohu tužkou napsaná současná signatura Národní knihovny). On the right side, a list of related records is shown, including 'Homiliae in evangelium s.Lucae', 'Er-Targyn', 'Te Deum Laudamus in D a Canto, Alto, Tenore, Basso, Violino Primo, Violino Secundo, Viola di Alto, Oboe Primo, Oboe Secundo, Clarino Primo, Clarino Secundo, Tympani Con Organo. Del: Sig: P: C: Vogel', 'Kyz-Zhibek: the Poem', 'Wir Ferdinandt der Ander', and 'Breviarium'. A 'Search results' callout box is overlaid on the bottom left of the screenshot.

see <http://v3.manuscriptorium.com>

Basic features: study

Overview

Detail

Facsimile (135)

XML



Graduale Dominicale

59.R.5098; Národní knihovna České republiky; Praha; Česko

Identification

Identifier set20100108_182_16

URI http://www.manuscriptorium.com/apps/index.php?direct=record&pid=set20100108_182_16

Shelf-mark 59.R.5098

Repository Národní knihovna České republiky

Settlement Praha

Country Česko



About the document

Title Graduale Dominicale

Format codex

Extent 66 ff. 160 205

Medium chart

Provenance V pravém horním rohu tužkou napsaná současná signatura Národní knihovny.

Basic features: study

Overview

Detail

Facsimile (135)

XML

☆ Graduale Dominicale

59.R.5098; Národní knihovna České republiky; Praha; Česko

▸ Identification

▸ Heading

▾ Contents

Rukopis obsahuje proměnlivé mešní zpěvy pro neděle a svátky řazené podle průběhu církevního roku.

▾ 1: Missa temp[or]e Adventus (4 části) 

Locus: 1r  - 1v 

Title: Missa temp[or]e Adventus

▸ 1.1: [Introitus] 

▸ 1.2: [Versus] 

▸ 1.3: Offert[orium] 

▸ 1.4: Co[mmun]io 

▸ 2: In Festo Patrocinii S. Josephi (4 části) 

Basic features: study

Overview

Detail

Facsimile (135)

XML



Graduale Dominicale

59.R.5098; Národní knihovna České republiky; Praha; Česko

★ 0



FC



FS

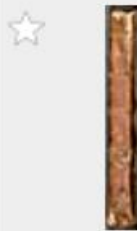

SP



1r



1v



2r



2v



3r



3v



4r



4v



5r



5v



6r



6v



7r



7v



8r



8v



9r



9v

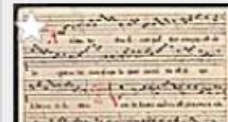
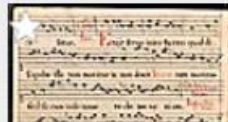

Basic features: study

Overview

Detail

Facsimile (135)

XML

☆ Graduale Dominicale

59.R.5098; Národní knihovna České republiky; Praha; Česko

```
<TEI>
  <teiHeader>
    <fileDesc>
      <titleStmt>
        <title/>
      </titleStmt>
      <publicationStmt>
        <p/>
      </publicationStmt>
      <sourceDesc>
        <msDesc xml:id="idset20100108_182_16" xml:lang="cze">
          <msIdentifier>
            <country key="xr">Česko</country>
            <settlement>Praha</settlement>
            <repository>Národní knihovna České republiky</repository>
            <idno>59.R.5098</idno>
          </msIdentifier>
          <head>
            <title>Graduale Dominicale</title>
            <origPlace?</origPlace>
            <origDate>1704</origDate>
          </head>
          <msContents>
            <summary>
              <note>
                <p>Rukopis obsahuje proměnlivé mešní zpěvy pro neděle a svátky řazené podle průběhu církevního roku.</p>
              </note>
            </summary>
          </msContents>
        </msDesc>
      </sourceDesc>
    </fileDesc>
  </teiHeader>
</TEI>
```

Basic features: advanced search



graduale dominicale

Words anywhere

Search

Refine

Search tools

Advanced search tools

Results 2

- ✘ Words anywhere: graduale* dominicale*
- ✘ AND With a digital copy
- ✘ AND Library: "Národní knihovna České republiky"

Add to favorite queries

★ **Graduale Dominicale**
59.R.5098; Národní knihovna České republiky; Praha; Česko

☆ **Graduale**
XII.F.20; Národní knihovna České republiky; Praha; Česko

Query summary
(can be modified)

Overview Detail Facsimile (135) XML

Dominicale

Národní knihovna České republiky; Praha; Česko

Identification

Identifier set20100108_182_16
URI http://www.manuscriptorium.com/apps/index.php?direct=record&pid=set20100108_182_16
Shelf-mark 59.R.5098
Repository Národní knihovna České republiky
Settlement Praha
Country Česko



About the document

Title Graduale Dominicale
Format codex
Extent 66 ff. 160 205
Medium chart
Provenance V pravém horním rohu tužkou napsaná současná signatura Národní knihovny

Contents

Basic features: advanced search

 Words anywhere Refine

Filter search results

Available filters

Facsimile 472

Library

Filters applied

Words anywhere: testament*

★ **Graduale Dominicale**
59.R.5098; Národní knihovna České republiky; Praha; Česko

☆ **Biblia Veteris et Novi testamenti**
Johannes Andreae; Johannes de Deo (Hispanus); Stephanus Langton
Osek 72; Národní knihovna České republiky; Praha; Česko

☆ **Psalterium (Žaltář)**
XVII.J.5; Národní knihovna České republiky; Praha; Česko

☆ **Biblia - Novum testamentum**
Stephanus Langton
XXIII.B.1; Národní knihovna České republiky; Praha; Česko

☆ **Biblia, Vetus testamentum (Genesis-Psalmi)**
Stephanus Langton
I.A.29a; Národní knihovna České republiky; Praha; Česko

☆ **Biblia, Novum testamentum**

☆ **Graduale Dominicale**

59.R.5098; Národní knihovna České republiky; Praha; Česko

```
<TEI>
  <teiHeader>
    <fileDesc>
      <titleStmt>
        <title/>
      </titleStmt>
      <publicationStmt>
        <p/>
      </publicationStmt>
      <sourceDesc>
        <msDesc xml:id="idset20100108_182_16" xml:lang="cze">
          <msIdentifier>
            <country key="xr">Česko</country>
            <settlement>Praha</settlement>
            <repository>Národní knihovna České republiky</repository>
            <idno>59.R.5098</idno>
          </msIdentifier>
          <head>
            <title>Graduale Dominicale</title>
            <origPlace?</origPlace>
            <origDate>1704</origDate>
          </head>
        </msDesc>
      </sourceDesc>
    </fileDesc>
  </teiHeader>
</TEI>
```

see <http://v3.manuscriptorium.com>

Basic features: browse a facsimile

Click thumbs
to popup the detailed image

The screenshot displays the Urvatagirk digital library interface. On the left, a search bar contains the text "Library: armenia*" and a red button labeled "Add to favorite queries". Below this, a red banner identifies the library as "Urvatagirk: National Library of Armenia, Yerevan, Armenia (Republic)". The main area features a grid of 42 manuscript thumbnails, each with a small star icon in the top right corner. The thumbnails are arranged in a 6x7 grid, with the first cell containing a thumbnail labeled "FC" and the remaining cells containing thumbnails labeled from "0001" to "0041". A blue callout box with a white border points to the thumbnail labeled "0003", containing the text "Click thumbs to popup the detailed image". To the right of the grid, a list of search results is displayed, each with a star icon and a close button. The results include:

- ★ *Homiliae in evangelium s. Lucae* Gregorius Magnus S10 A 002; Knihovna Západočeského muzea v Plzni; Plzeň
- ★ *Er-Targyn* 097978; National Library of the Republic of Kazakhstan; Almaty, Kazakhstan
- ★ *Te Deum Laudamus in D a Canto, Alto, Tenore, Basso, Violino Primo, Violino Secundo, Viola di Alto, Oboe Primo, Oboe Secundo, Clarino Primo, Clarino Secundo, Tympani Con Organo. Del: Sig: P: C: Vogel* 3r 59.R.1458; Národní knihovna České republiky; Praha; Česko
- ★ *Kyz-Zhibek: the Poem* Zhusupbek-Khodji (Shaikhulislamuly) 179754; National Library of the Republic of Kazakhstan; Almaty, Kazakhstan
- ★ *Wir Ferdinandt der Ander* S10 C 022; Knihovna Západočeského muzea v Plzni; Plzeň
- ★ *Breviarium* S10 A 005; Knihovna Západočeského muzea v Plzni; Plzeň
- ★ *Kabala* S10 A 004; Knihovna Západočeského muzea v Plzni; Plzeň
- ★ *Testamentum Vetus (Genesis usque Job)* 20-D-5 (13939) Hs. Kynžvart 37; Zámek Kynžvart; Kynžvart; Česká republika
- ★ *Bibliche Zeitrechnung des alten und neuen Testaments.* 17-E-11 (11588); Zámek Kynžvart; Česká republika - Státní památkový ústav v Plzni; Lázně Kynžvart; Česko (Czechia)

see <http://v3.manuscriptorium.com>

Basic features: browse a facsimile

Floating window
(can be minimized, keeps open until closed)

The image displays a screenshot of the Manuscriptorium website interface. On the left, a floating window shows a facsimile of a manuscript page with Armenian text in red and black ink. The text is written in a historical script, and there are some annotations in purple ink. The page number '136' is visible. On the right, the main website interface is shown, featuring a grid of thumbnail images of manuscript pages, numbered from 0001 to 0034. The interface includes a search bar, navigation tools, and a list of search results on the right side. The search results list various manuscripts with their titles, identifiers, and locations.

Urbatagirik | 0003

Urbatagirik

National Library of Armenia; Yerevan; Armenia (Republic)

0001 0002 0003 0004 0005 0006

0008 0009 0010 0011 0012 0013

0015 0016 0017 0018 0019 0020

0022 0023 0024 0025 0026 0027

0029 0030 0031 0032 0033 0034

Homiliae in evangelium s. Lucae
Gregorius Magnus
510 A 002; Knihovna Západočeského muzea v Plzni; Plzeň

Er-Targyn
097978; National Library of the Republic of Kazakhstan; Almaty; Kazakhstan

Te Deum Laudamus in D a Canto, Alto, Tenore, Basso,
Violino Primo, Violino Secondo, Viola di Alto, Oboe Primo,
Oboe Secondo, Clarino Primo, Clarino Secondo, Tympani Con
Organo. Del: Sig: P: C: Vogel
3r
59.R.1458; Národní knihovna České republiky; Praha; Česko

Kyz-Zhibek: the Poem
Zhusupbek-Khodji (Shaikhulislamuly)
179754; National Library of the Republic of Kazakhstan; Almaty; Kazakhstan

Wir Ferdinandt der Ander
510 C 022; Knihovna Západočeského muzea v Plzni; Plzeň

Breviarium
510 A 005; Knihovna Západočeského muzea v Plzni; Plzeň

Kabala
510 A 004; Knihovna Západočeského muzea v Plzni; Plzeň

Testamentum Vetus (Genesis usque Job)
20-D-5 (13939) Hs. Kynžvart 37; Zámek Kynžvart; Kynžvart; Česká republika

Biblische Zeitrechnung des alten und neuen Testaments.
17-E-11 (11588); Zámek Kynžvart; Česká republika - Státní památkový ústav v Plzni; Lázně Kynžvart; Česko (Czechia)

see <http://v3.manuscriptorium.com>

Basic features: browse a facsimile

Multiple images can be opened
(page comparison, parallel reading)

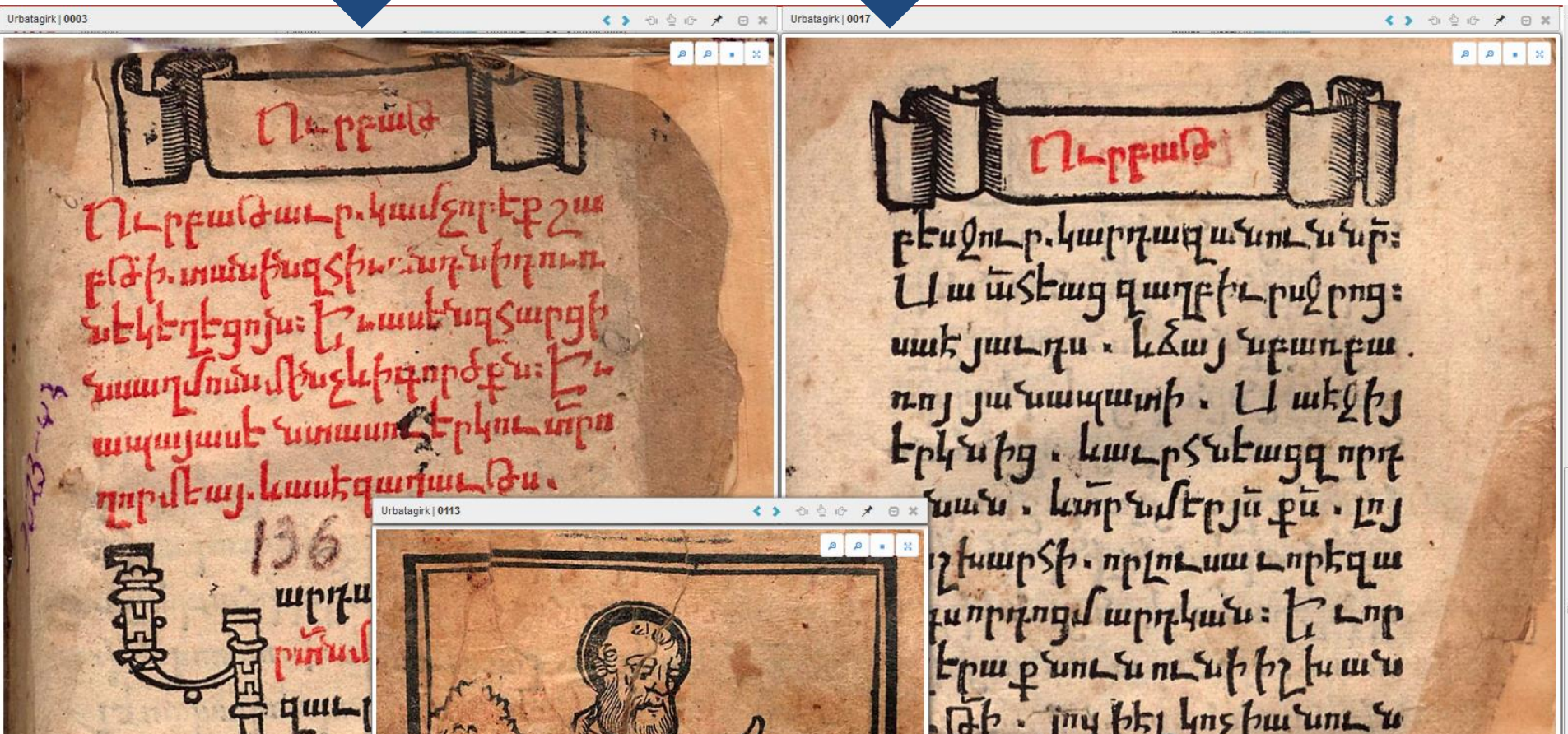

see <http://v3.manuscriptorium.com>

Basic features: browse a facsimile

Multiple images from different documents can be opened (page comparison, parallel reading)

The screenshot displays a digital library interface with several overlapping windows showing facsimiles of historical documents. The main window in the foreground shows a page from the 'Biblia, Vetus testamentum | 1v' with large red initials 'pro' and 'lus' and a detailed illustration of a cherub holding a scroll. Other windows show a page from 'Psalterium (Žaltář) | 1v' with a large decorated initial 'S' and a page from 'Biblia, Vetus testamentum | FS' with a cherub illustration. The interface includes a search bar, a list of search results on the left, and a user profile 'tomas logged in' in the top right. The search results list various documents, including 'Biblia - Novum testamentum' by Stephanus Langton, 'Biblia, Vetus testamentum (Gen)' by Stephanus Langton, 'Biblia, Novum testamentum' by I.A. 29b, 'Biblia, Vetus testamentum' by I.A. 52, 'Biblia Veteris et Novi testamenti' by Stephanus Langton, 'Psalterium, horae, orationes' by Pseudo-Franciscus Petrarca, 'Epistolae et tractatus' by Petrus Blesensis, 'Bible, Starý zákon' by XVII.A.36, 'Biblia, Vetus testamentum (inco)' by X.B.19, 'Biblia, Vetus testamentum' by Alexander de Villa Dei, 'Bible (Biblia)' by XVII.A.37, 'Městská kniha V radní' by Archiv města Jihlava, 'Opera varia, epistolae' by Thascius Caecilius Cyprianus Carthaginiensis, and 'Sborník husitských listin a synodních ustanovení, kopířan' by listů Arnošta z Harrachu.

Basic features: favorites

Personal account needed

The screenshot displays the Manuscriptorium website interface. At the top, the search bar contains the word "biblia" and the search type is set to "Words anywhere". The user "tomas" is logged in. The search results page shows 3965 results. The left sidebar lists search results, with the top one, "Biblia Veteris et Novi testamenti" by Johannes Andreae, Johannes de Deo (Hispanus), and Stephanus Langton, highlighted in red. The main content area shows a grid of manuscript thumbnails, with the top-left thumbnail circled in blue. The right sidebar shows a detailed view of the selected manuscript, including its title, author, and a list of folios (FC, FS, SP, etc.). A blue callout box at the top right indicates "Personal account needed".

see <http://v3.manuscriptorium.com>



MANUSCRIPTORIUM

2. Partners' essentials

Aggregation principles: fundamentals

Individual approach to cooperating partners:

- We respect various conditions within individual institutions.
- We do not interfere with internal processes.
- Instead we adapt Manuscriptorium input interfaces by means of adapted **connectors**.

patre ⁊ spū scō ppetuo temp̄r,
S E R V O L A Y R E N T I I
R OGO vos ER̄s dñi ut memores sitis salu
animarū ur̄arū: & ne cuius malis oīs

Aggregation principles: fundamentals

Distributed data repositories principle

- Each digital document consists (at least) of **data** (images) and **metadata** (descriptions, structural metadata).
- **Images are distributed** in their original repositories (managed by its owner/managing institution).
- **Metadata are aggregated** into the Manuscriptorium.
- Final document is completed within end-users browser.

Aggregation principles: fundamentals

Partners should

- setup their own webserver and data space,
- make the images accessible via HTTP protocol from the webserver,
- export descriptive records and pass it to Manuscriptorium,
- provide Manuscriptorium with image lists (URLs to webserver).

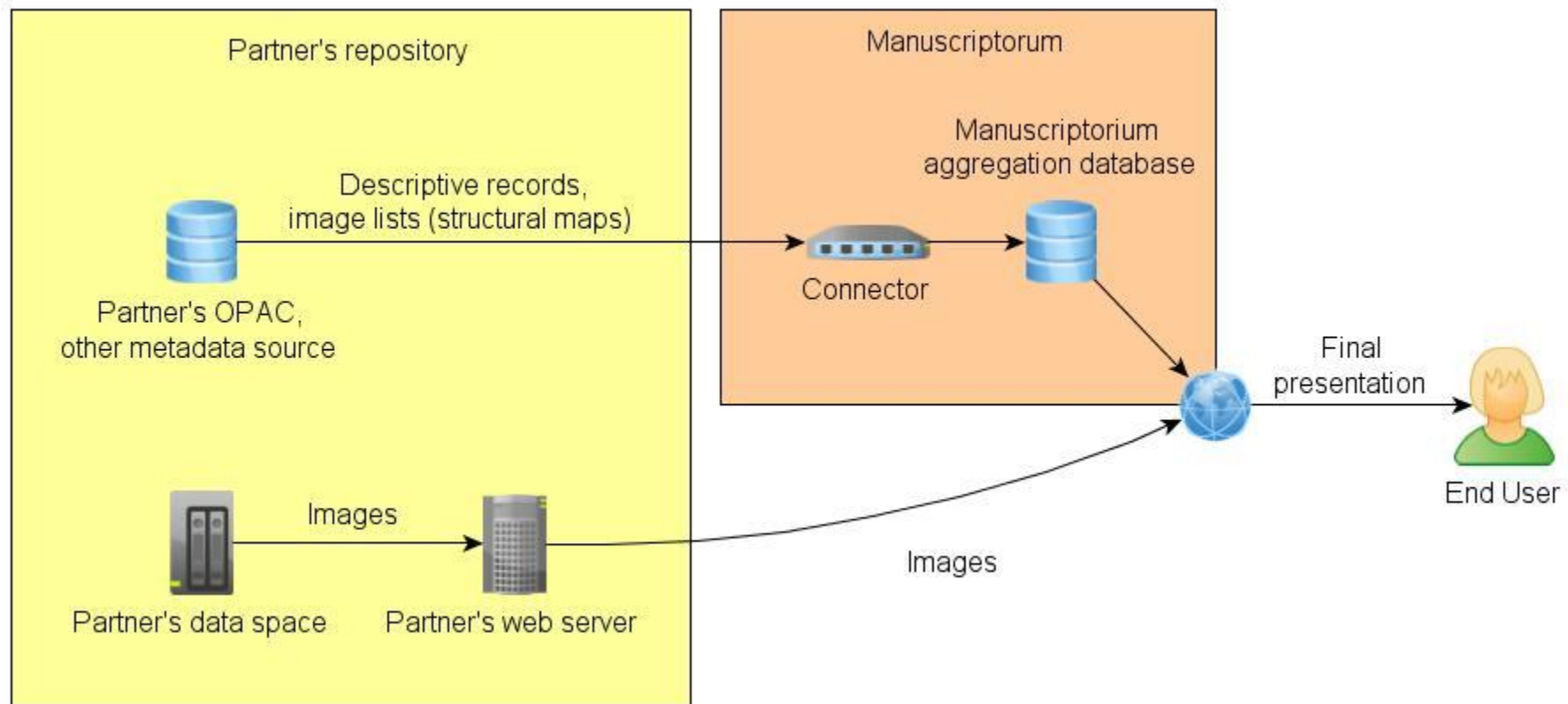

Aggregation principles: compatibility

Compatibility with Manuscriptorium: **data**

- Images formats should be supported by major browsers: **we accept JPEGs, GIFs, PNGs.**
- TIFF, JPEG 2000, MrSID, DjVu, PDFs – are not supported (without a plugin).

Aggregation principles: compatibility

Compatibility with Manuscriptorium: **metadata**

- Manuscriptorium works with standard TEI P5 as an internal format.
- Partners provide their metadata in *TEI P5* **OR** in their *native formats* accordingly to their individual decision.

Aggregation principles: ways of cooperation

Small scale projects: import of individual documents.

Metadata often does not exist or is not directly compatible.

- Partner creates new metadata with our on-line tools:
www.manuscriptorium.com/apps/m-tool/m-tool.php

- Partner uploads created metadata with our on-line tools:

 - <http://www.manuscriptorium.com/apps/candidates/login.php?envLang=eng>

 - (login needed, see Contacts slide)

This is rather a „*manual*“ way of cooperation.

Aggregation principles: ways of cooperation

Larger scale projects: metadata already exists.

- Batch import of documents is possible.
- If metadata is not directly compatible: Manuscriptorium creates an individual connector to get compatible with the individual partners.

(e.g. connector converts for instance MARC 21 into TEI P5 etc.)

- Where possible OAI-PMH is the preferred way of accessing the metadata (fully automated way of cooperation)
 - Other (semi-automated) ways of accessing the metadata are also supported.

Aggregation principles: ways of cooperation

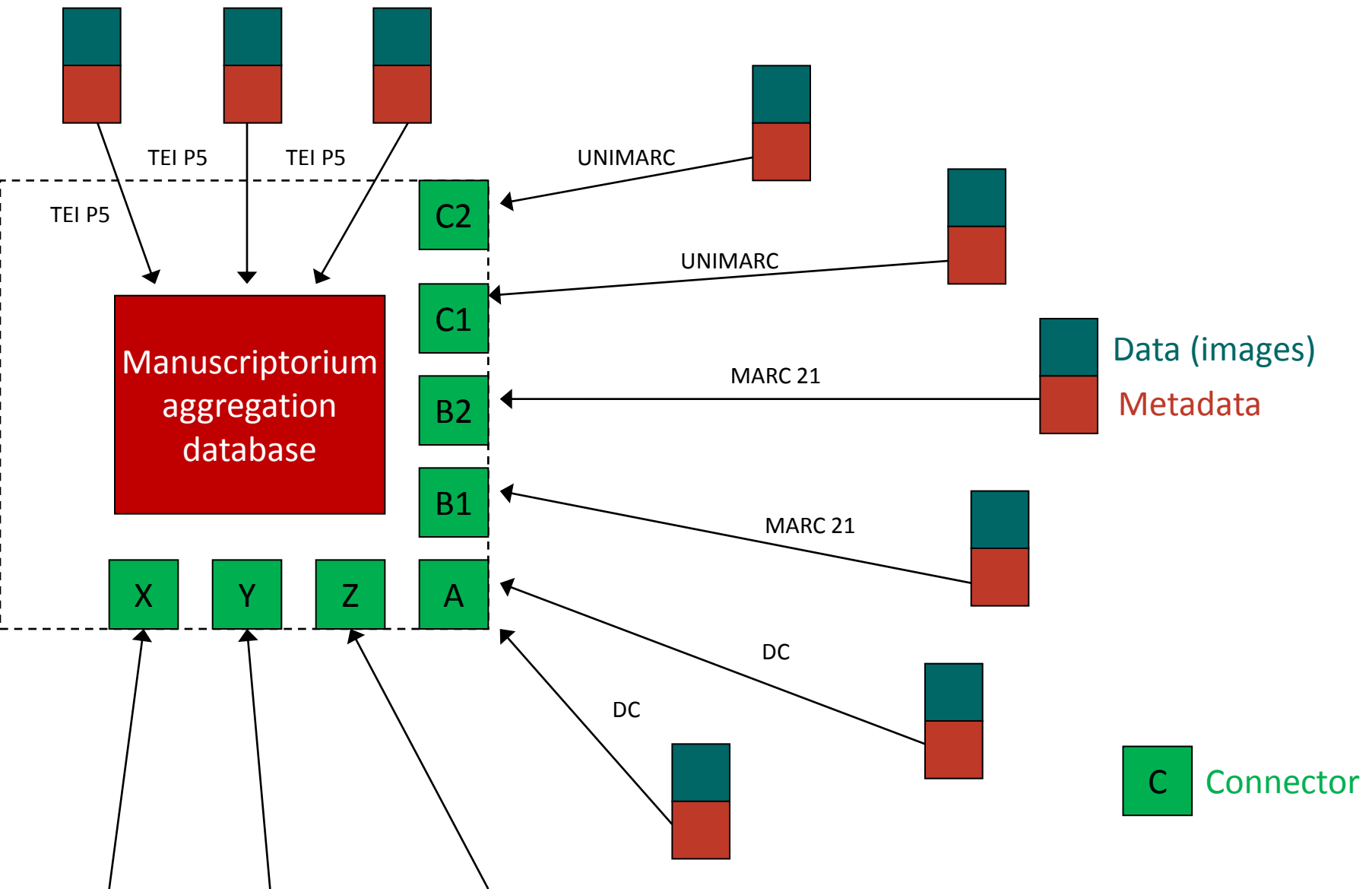

Aggregation principles: ways of cooperation

Harvesting of non-TEI metadata

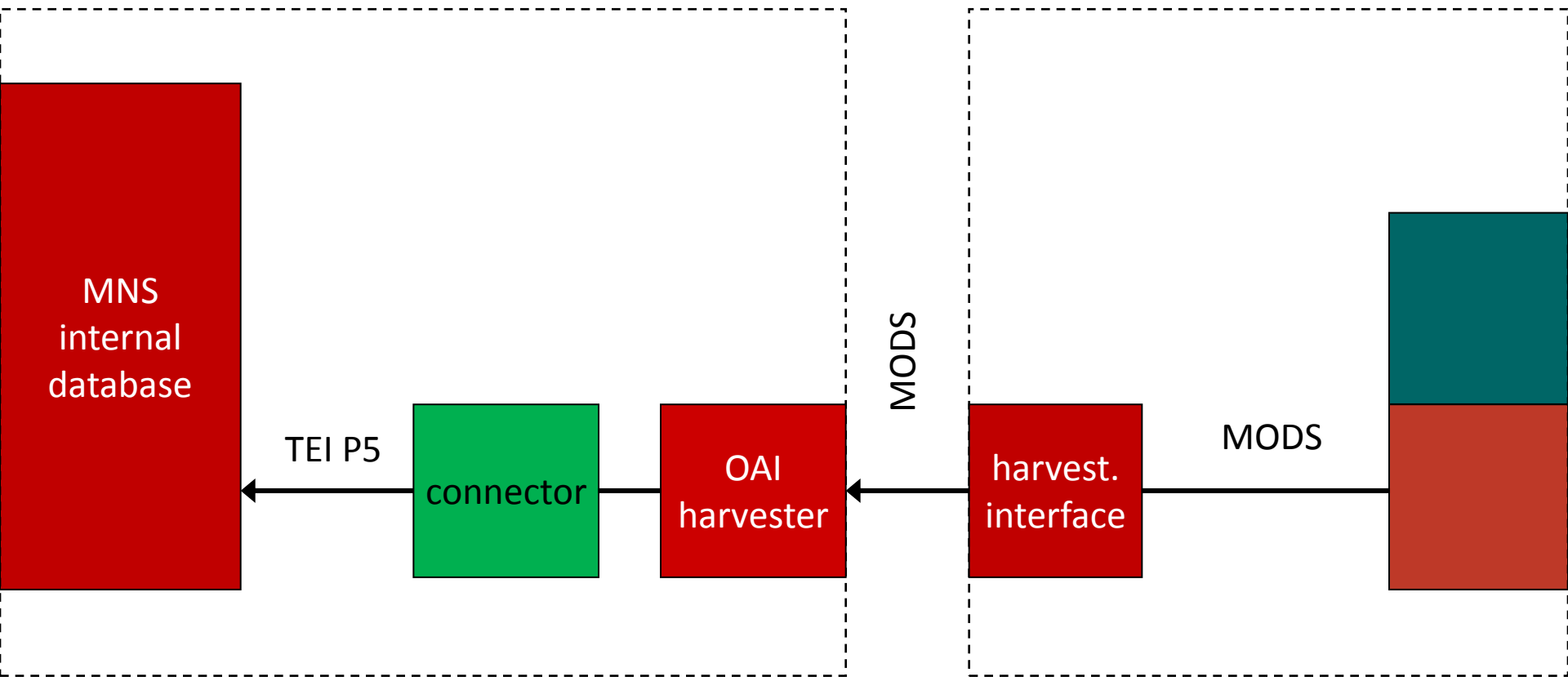

Aggregation principles: ways of cooperation

Semi-automated processing of non-TEI metadata

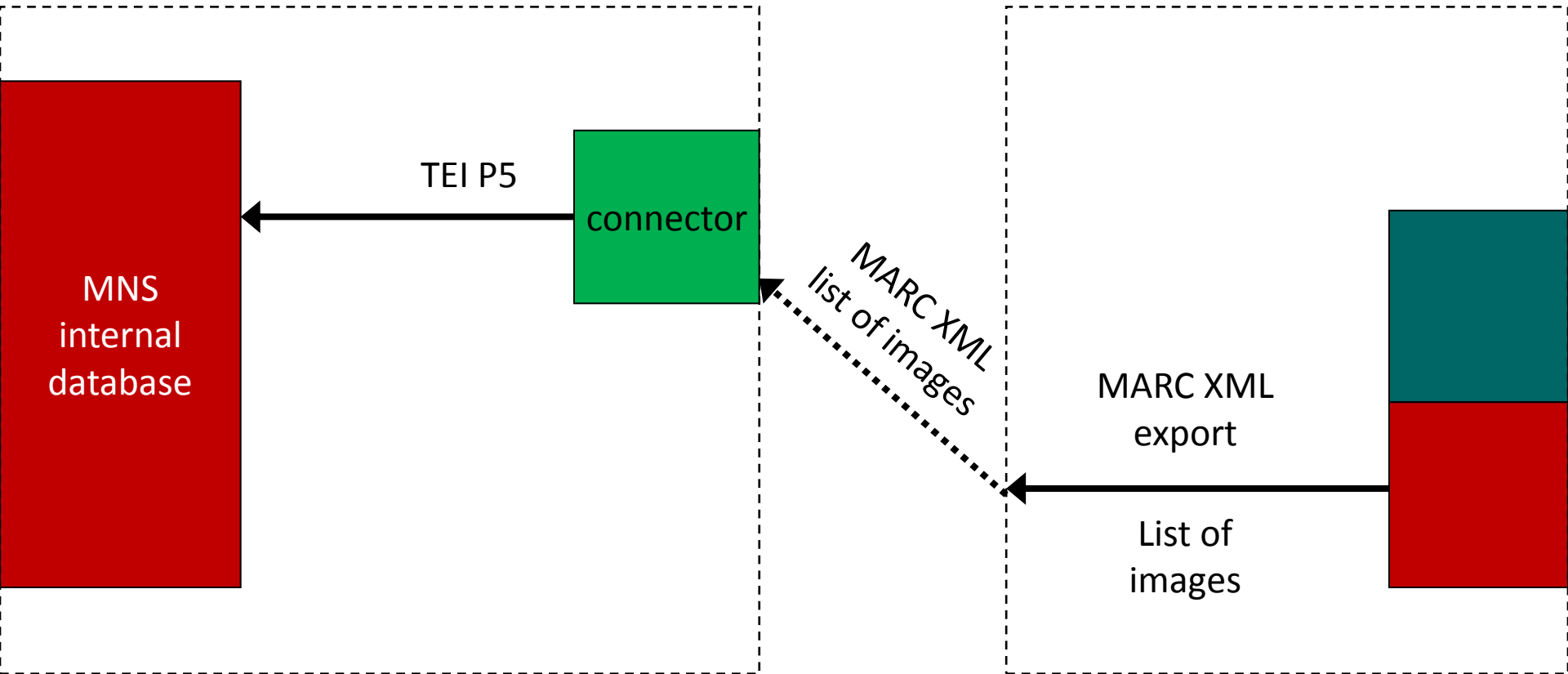



MANUSCRIPTORIUM

3. Something more

More advanced features:

1. Highlighted items in the homepage
2. Persistent links to documents
3. Saved (favorite) queries
4. Document collections
5. Virtual documents
6. Annotation module
7. Widgets and sharing possibilities

On-line demo at <http://v3.manuscriptorium.com>

Contacts:

1. <http://w3.manuscriptorium.com>
2. info@manuscriptorium.com
3. +420 311 611 237

See on-line at <http://v3.manuscriptorium.com>

Credits:

Manuscriptorium is provided by the National Library of the Czech Republic (www.nkp.cz).

Development and technical service is provided by AiP Beroun s.r.o. (www.aipberoun.cz).

Manuscriptorium is powered by **GULLIVER**: a highly customizable digital library tool by AiP Beroun s.r.o.

